

70% of Actual Size
Direct Digital

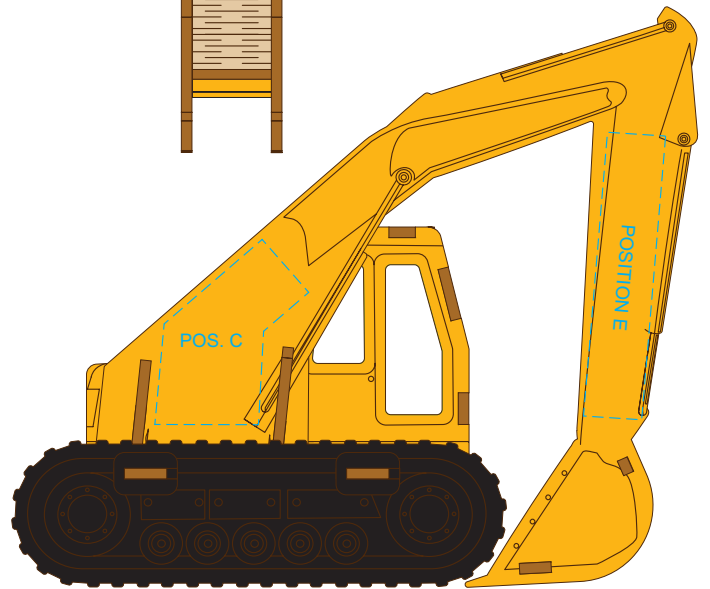

Up to a 2mm tolerance is expected for alignment of the printed artwork against the engraved lines. Slight inconsistencies are to be considered acceptable if the artwork is printed over an engraved line.

Customisable Colour Groups

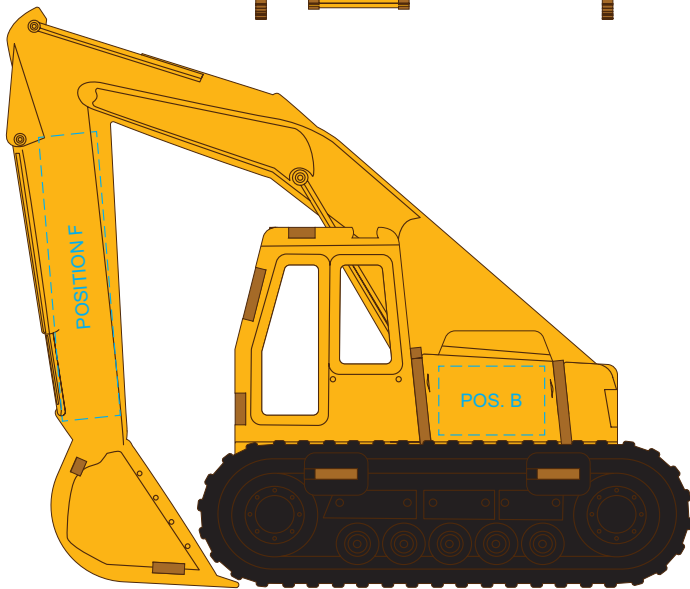
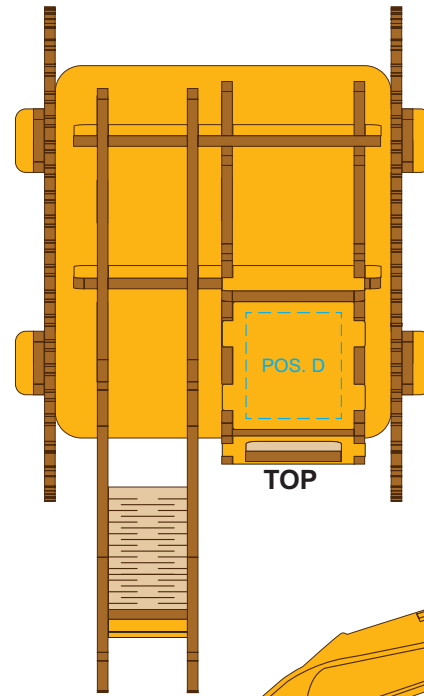
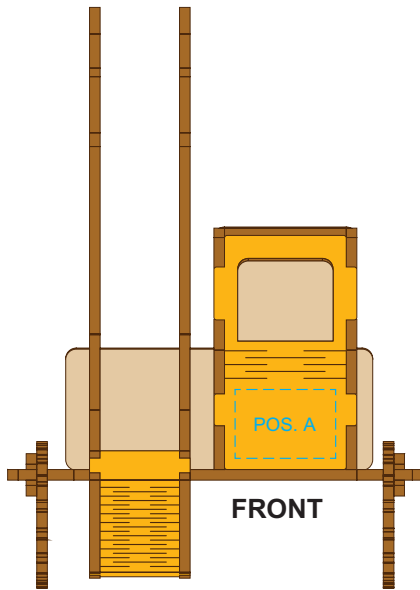

Blue Line = Safe area for Arwork

100% of Actual Artwork Print Area

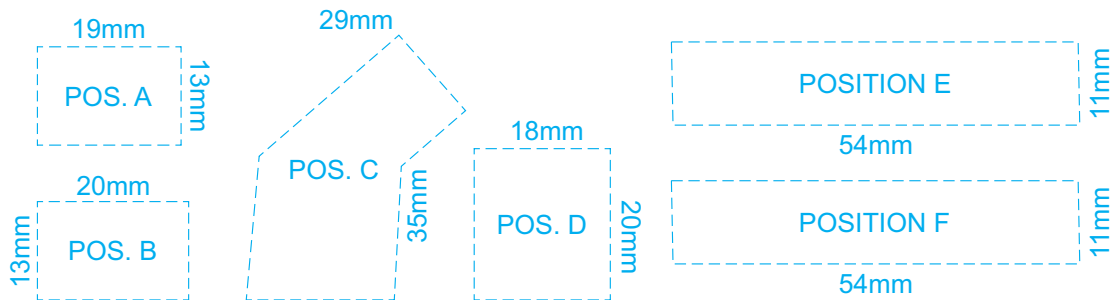

BRANDING SPECIFICATION - Excavator Wooden Model - 124035

Each colour group can be customised to any single colour. Please provide CMYK / PMS values (close matched) for each colour group or specify if solid colour fill is not required. The product is provided flat packed in a cardboard sleeve with assembly instructions.

PRESET
DESIGN
1

Customisable Colour Groups



70% of Actual Size
Direct Digital

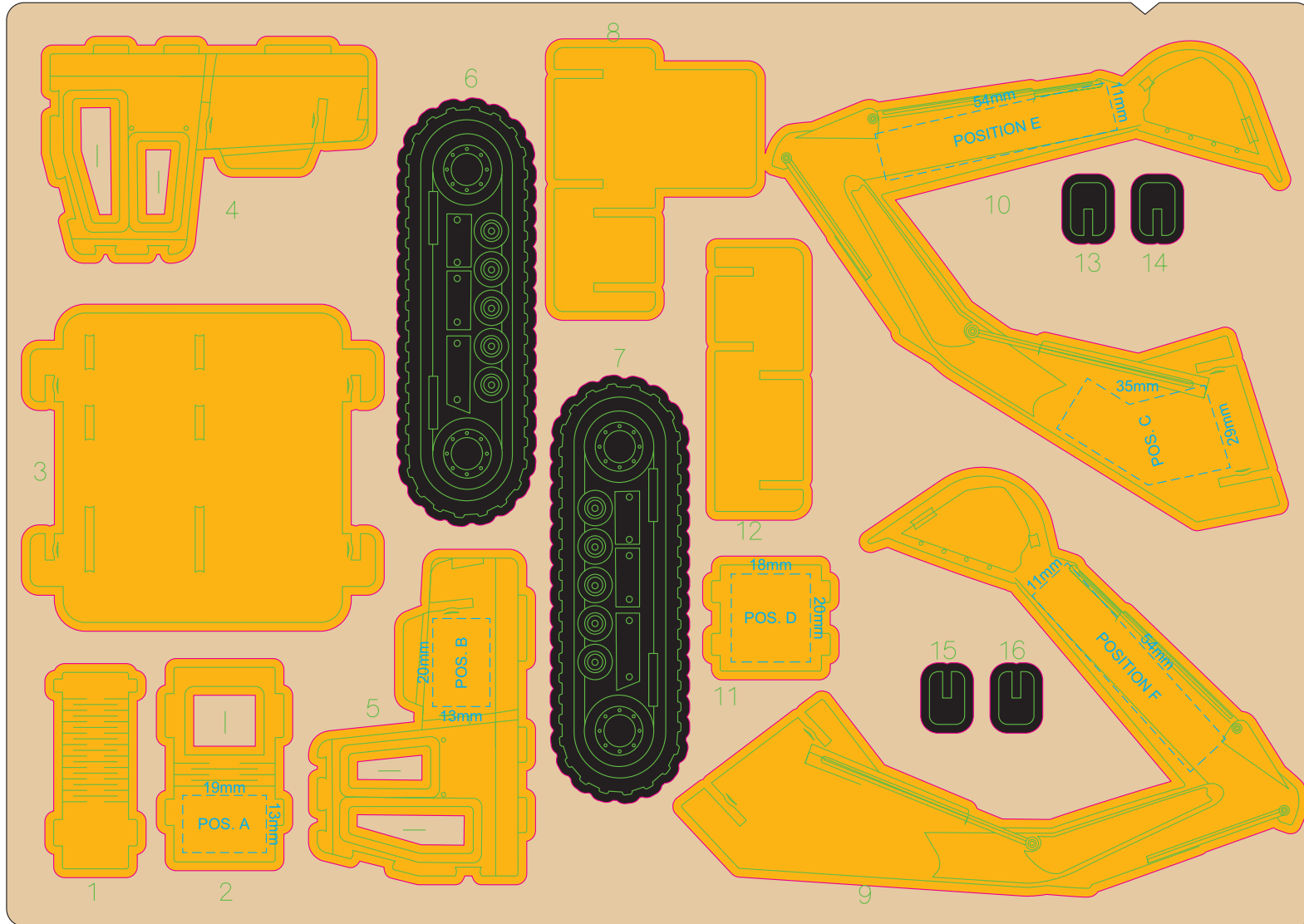

 WOOD TONE (Not included in print)

Blue Line = Safe area for logo
Green Line = Maximum print area
Pink Line = Bleed off to here

BRANDING SPECIFICATION - Excavator Wooden Model - 124035

Each colour group can be customised to any single colour. Please provide CMYK / PMS values (close matched) for each colour group or specify if solid colour fill is not required. The product is provided flat packed in a cardboard sleeve with assembly instructions.

**CUSTOM
TEMPLATE**

70% of Actual Size
Direct Digital
(Custom Full Colour Design)

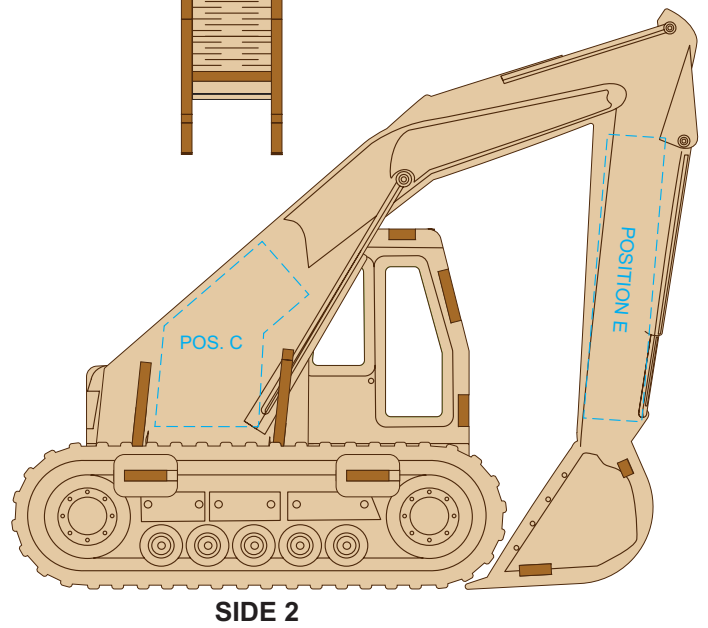
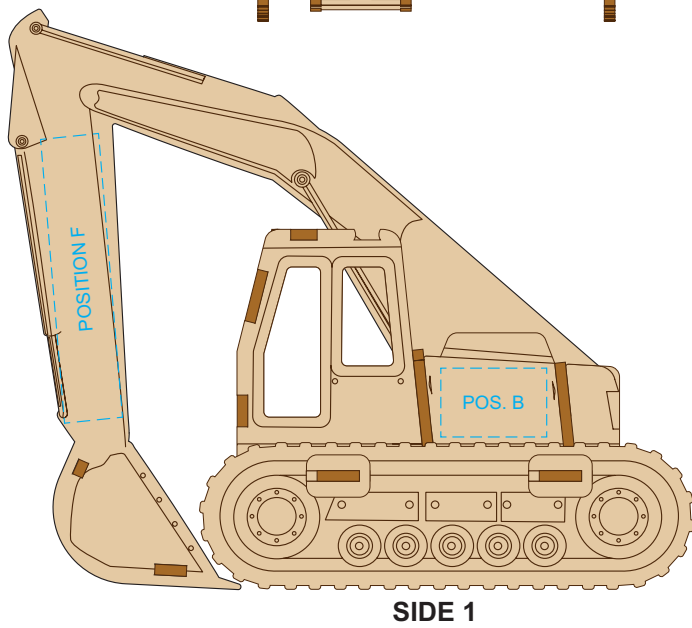
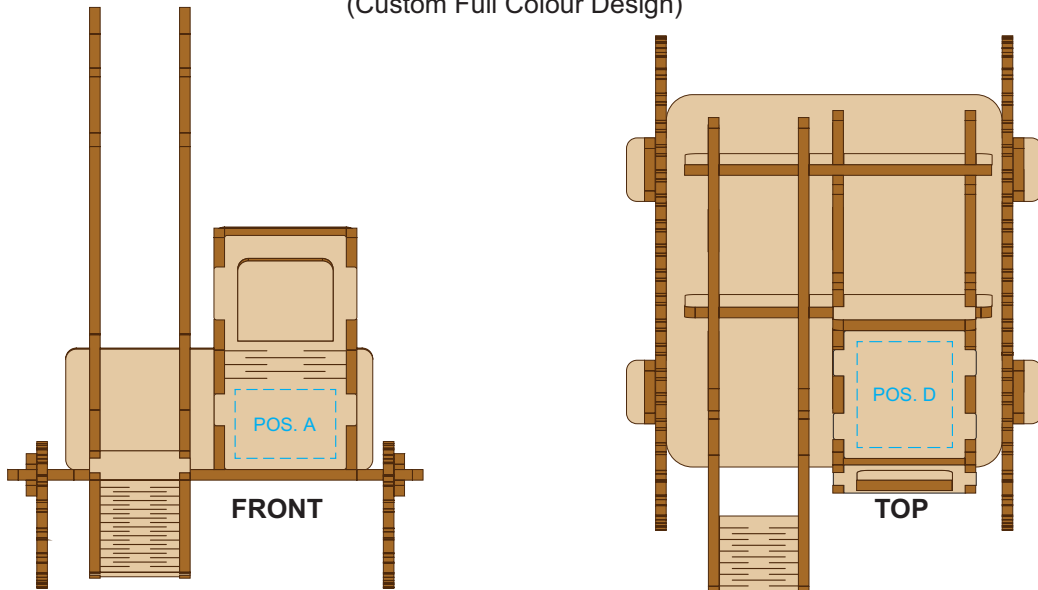

Up to a 2mm tolerance is expected for alignment of the printed artwork against the engraved lines. Slight inconsistencies are to be considered acceptable if the artwork is printed over an engraved line.

Blue Line = Safe area for Arwork
100% of Actual Artwork Print Area

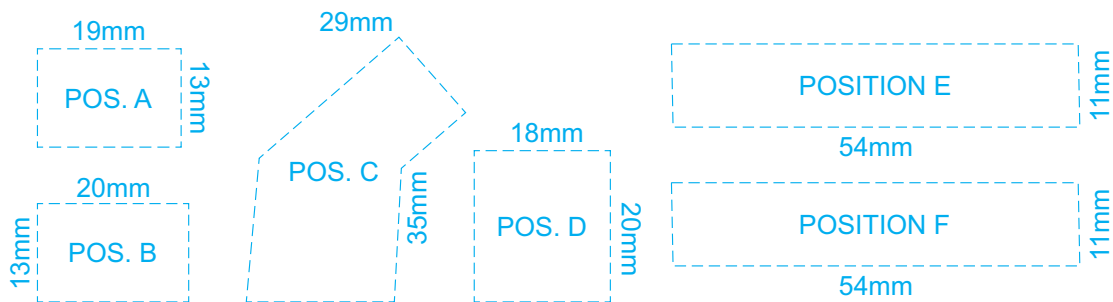

BRANDING SPECIFICATION - Excavator Wooden Model - 124035 New Stocks)

Each colour group can be customised to any single colour. Please provide CMYK / PMS values (close matched) for each colour group or specify if solid colour fill is not required. The product is provided flat packed in a cardboard sleeve with assembly instructions.

CUSTOM TEMPLATE

70% of Actual Size
Direct Digital
(Custom Full Colour Design)

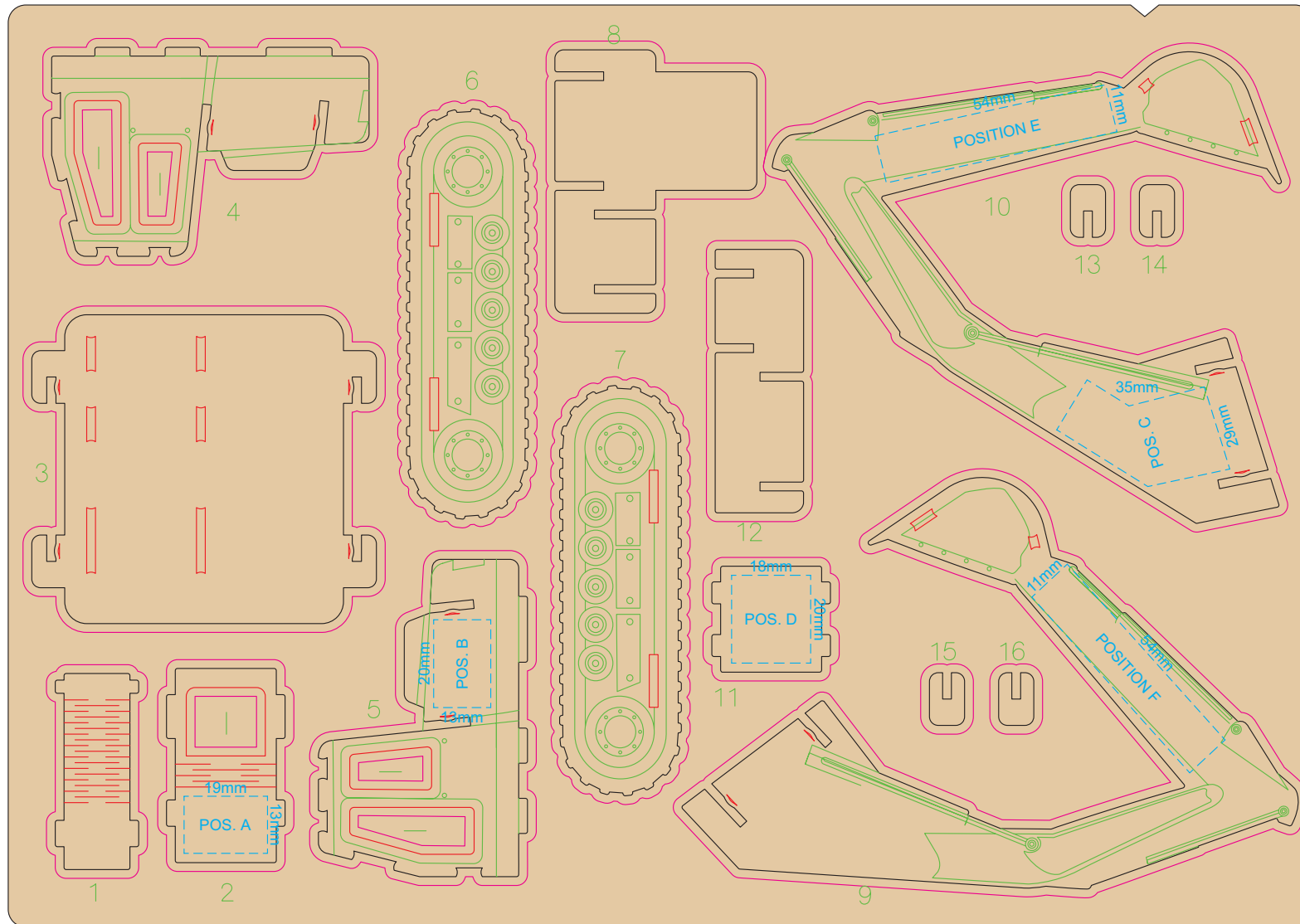

WOOD TONE (Not included in print)

Blue Line = The SIGNIFICANT PRINT AREA
(Keep all critical images & text within this box)

Red Line = Cut outs

(Avoid all critical images & text within this area)

Green Line = Engraved lines on the board

Black Line = Cut Marks of Edges

Pink Line = Bleed off to here

BRANDING SPECIFICATION - Excavator Wooden Model - 124035

Each colour group can be customised to any single colour. Please provide CMYK / PMS values (close matched) for each colour group or specify if solid colour fill is not required. The product is provided flat packed in a cardboard sleeve with assembly instructions.

70% of Actual Size
Screen Print (One Colour)

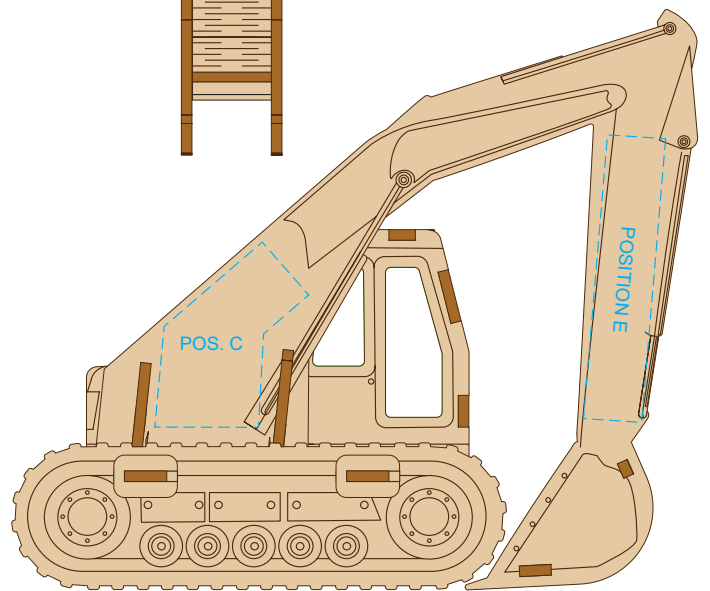
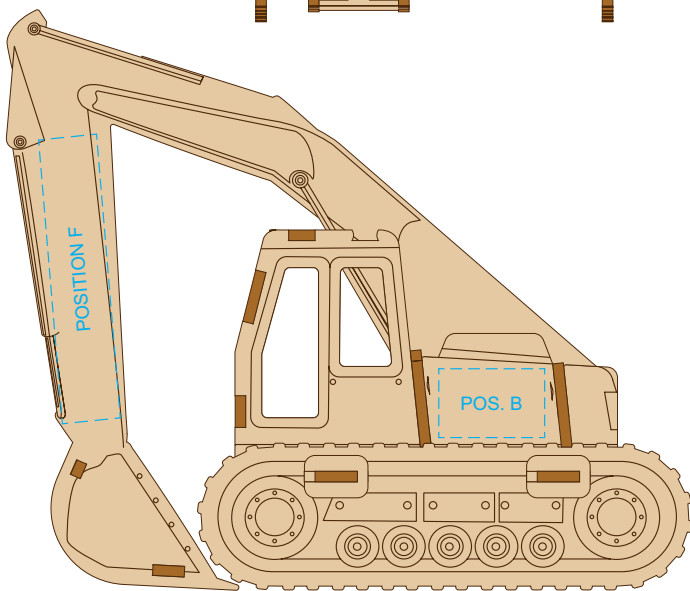
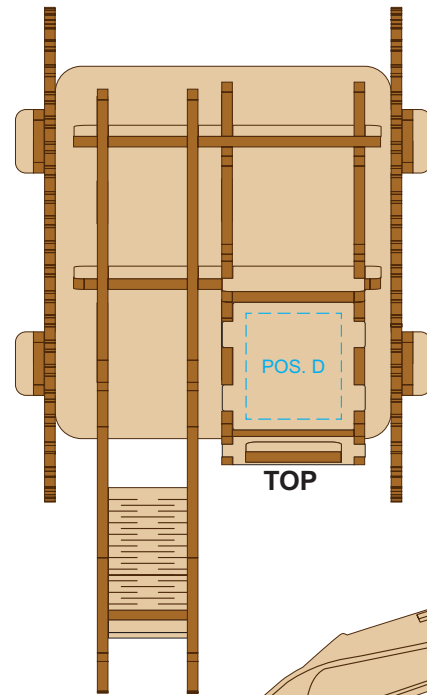
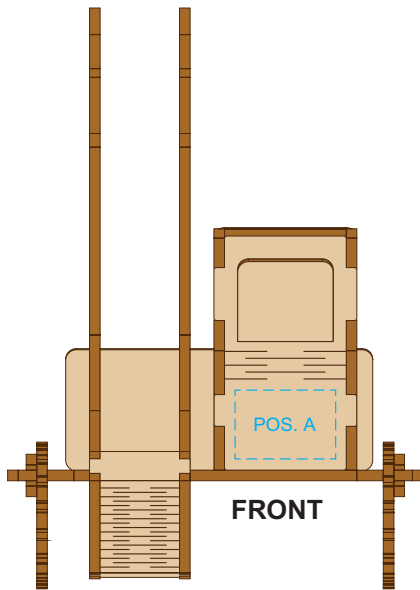

SIDE 1

SIDE 2

Up to a 2mm tolerance is expected for alignment of the printed artwork against the engraved lines. Slight inconsistencies are to be considered acceptable if the artwork is printed over an engraved line.

Blue Line = Safe area for Arwork

100% of Actual Artwork Print Area

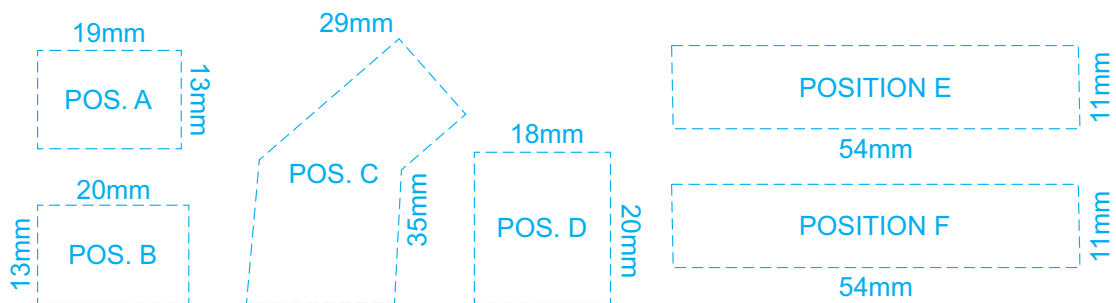

BRANDING SPECIFICATION - Excavator Wooden Model - 124035 New Stocks)

This product is made from natural wood, therefore some slight colour variation are considered acceptable. The product is provided flat packed in a cardboard sleeve with assembly instructions.

70% of Actual Size
Laser Engraving

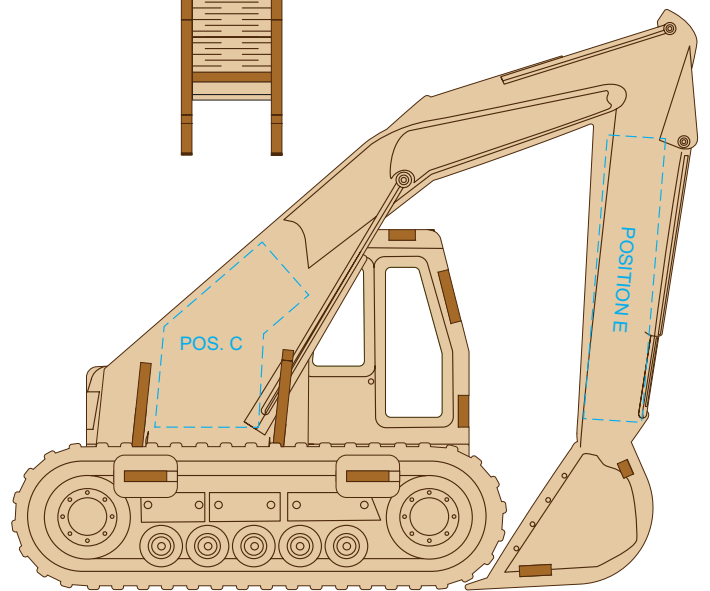
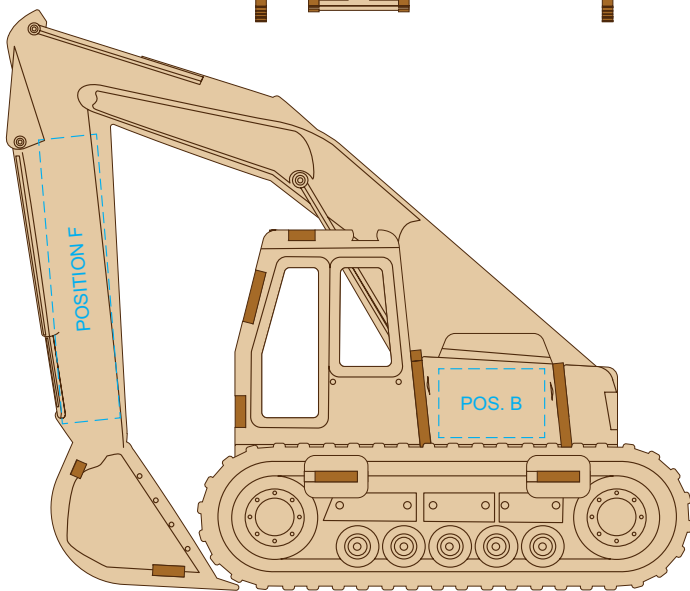
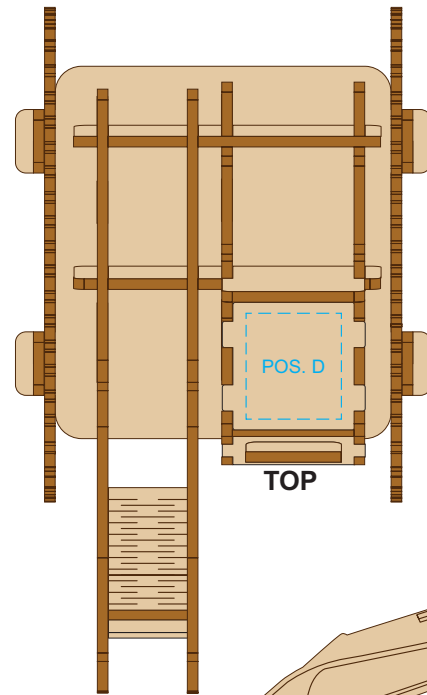
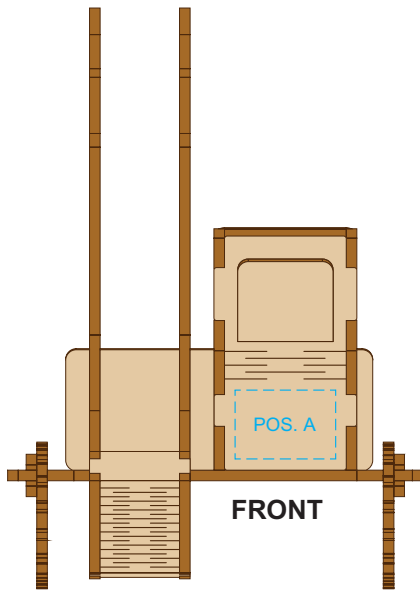

SIDE 1

SIDE 2

This product is a natural material, please allow for variances in grain pattern and engraving colour. Up to a 2mm tolerance is expected for alignment of the printed artwork against the engraved lines. Slight inconsistencies are to be considered acceptable if the artwork is printed over an engraved line.

Blue Line = Safe area for Artwork

 Laser engraves to a natural etch

100% of Actual Artwork Print Area

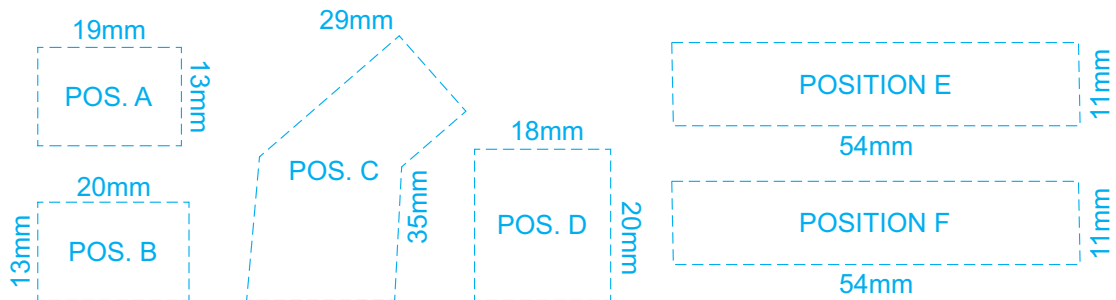

BRANDING SPECIFICATION - Excavator Wooden Model - 124035 New Stocks)

This product is made from natural wood, therefore some slight colour variation are considered acceptable. The product is provided flat packed in a cardboard sleeve with assembly instructions.

70% of Actual Size
Digital Packaging Print

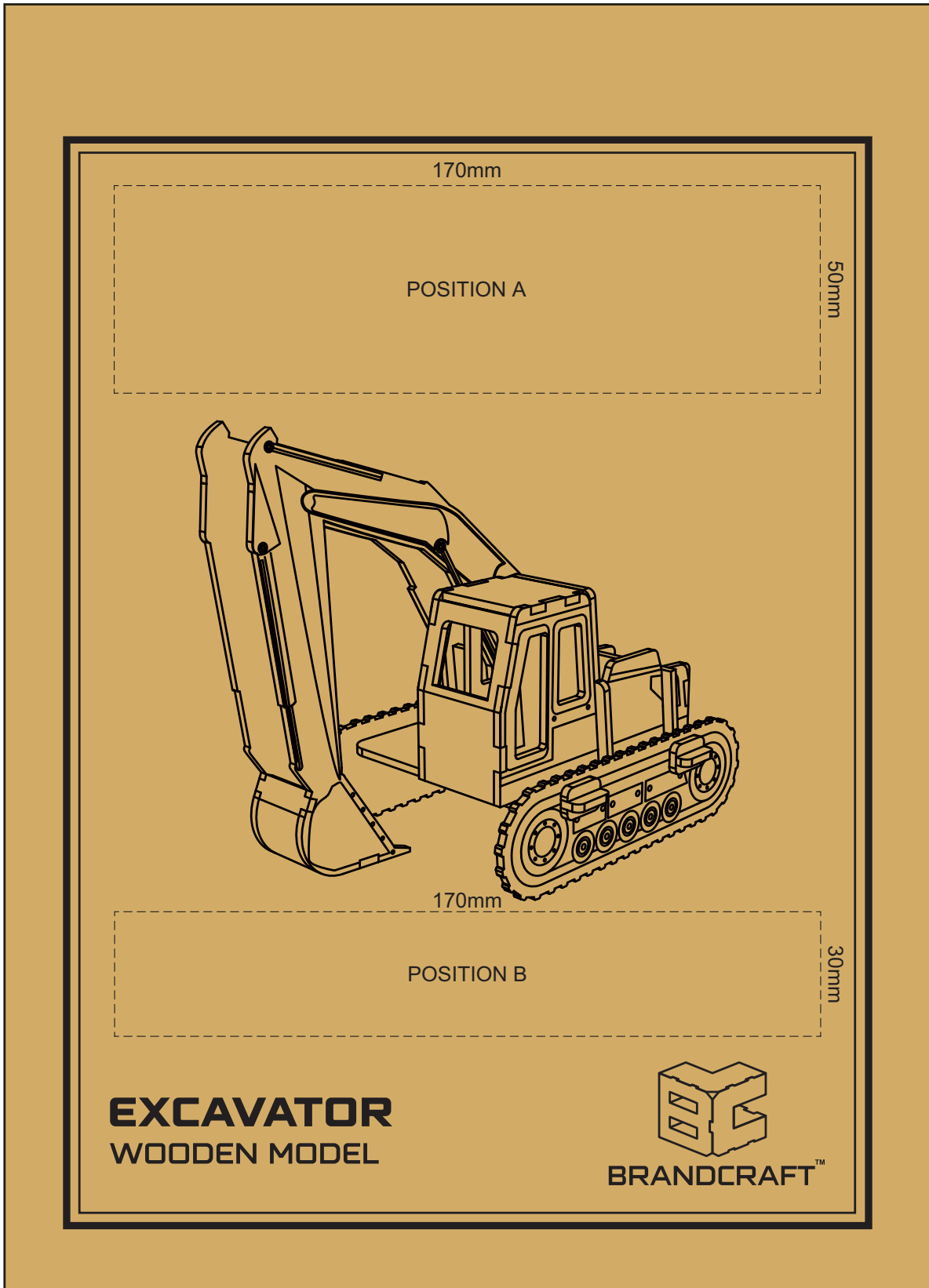

Artwork will be printed directly onto the product via CMYK printing (no white)
Colours will not be vibrant due to white ink not being available for this process.

BRANDING SPECIFICATION - Excavator Wooden Model - 124035 New Stocks)

The pre-printed cardboard sleeve will come with assembly instructions at the back.